

### High Current AC/DC Feedthrough Filter 55 Amp — High Reliability



- ✓ Excellent EMI filtering
- ✓ Compact and lightweight
- ✓ "C" Type Filter
- ✓ High Shock & Vibration
- ✓ High Reliability per MIL-PRF-49467
- ✓ MIL-PRF-55681, MIL-PRF-123, SCD available
- ✓ CDR and JAN Reliability levels available

### Voltage & Capacitance

55A		Capacitance $\mu\text{F}$																					
		.01	.015	.022	.033	.047	.068	.1	.15	.22	.33	.47	.68	1.0	1.5	2.2	3.3	4.7	6.8	10	15	22	
Rated Voltage	Vdc	50						+					+					+			+		
		100						+					+					+			+		
		200						+					+					+			+		
		500						+					+					+			+		
Rated Voltage	Vac	120		+			+																
		250		+																			

+ Standard Values

### Insertion Loss

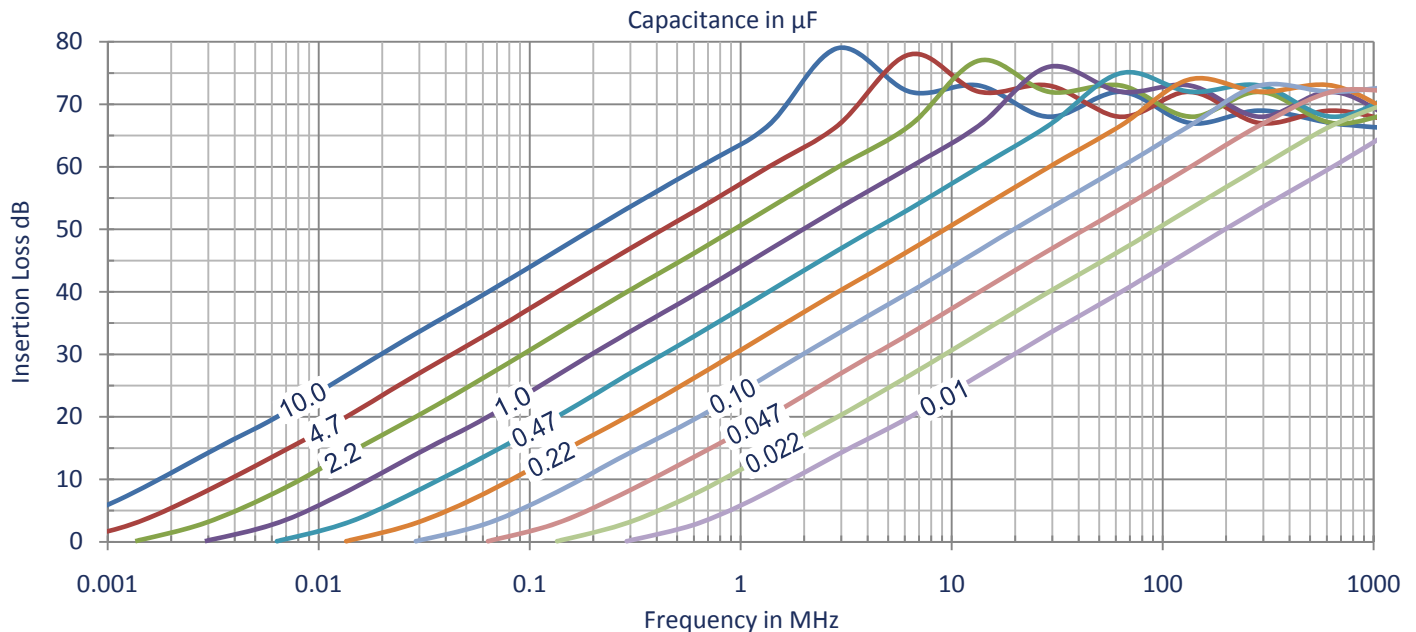

### High Reliability

MIL-C-49467 Group A (Custom units to MIL-C-55681, MIL-C-123 or customer SCD available)

Parameter	Value	Specification
Burn In	125°C / Rated Voltage / 96 hours	MIL-STD-202 Method 108A Cond A
Thermal Shock	-55°C to +125°C / 5 cycles	MIL-STD-202 Method 107D / Cond B Modified
Altitude	70,000' (21.3km or 33mm Hg)	
Vibration (high freq)	0.06"DA / 20g <sub>pk</sub> 10Hz-3kHz	MIL-STD-202 Method 204D / Cond F
Vibration (Random)	11.6g <sub>rms</sub> 50Hz – 2kHz, 90min	MIL-STD-202 Method 214 / Cond D

### Specifications

Parameter	Value	Description / Specification / Method
Current	55 Amperes	50, 55, 140, 175, 250, & 400 Amps available
Insertion Loss	See Performance Curve on page 1	Per Capacitor Value
RF Current	10A <sub>rms</sub>	
Insulation Resistance	100ΩF (100MΩ Maximum) at 25°C	MIL-STD-202 Method 302
Dielectric Withstand Voltage	250% Rated Voltage (50mA 5s)	MIL-STD-202 Method 301
Dissipation Factor (DF)	3% Maximum	MIL-STD-202 Method 306
Voltage Drop	18mV	Wire to Wire
Operating Temp	-55°C to +125°C	5A@125°C to 55A@105°C
Temperature Rise	19.9°C Typical at 55A	
Heat Rise Constant	9.8 to 20	C <sub>1</sub> in formula $\Delta T = C_1 \times W^{0.85}$
Storage Temperature	-55°C to +105°C	
Fungus	Non-Nutrient	MIL-HDBK-454A
Corrosion (metal finish)	5% NaCl / 35°C / 48 hrs	MIL-STD-202 Method 101D / Cond B
Humidity	98%RH 25°C-65°C	MIL-STD-202 Method 106E
Shock	50g – 11ms	MIL-STD-202 Method 213B / Cond A
Terminal Strength	Pull: 50lbs (23kg) Torque: 50"lbs (5.6Nm)	MIL-STD-202 Method 211A / Cond A & E
Reliability(MTBF)	500,000 hrs	MIL-HDBK-217F Cond - N2 A(IF) 70°C 50%V

### Mechanical Specifications

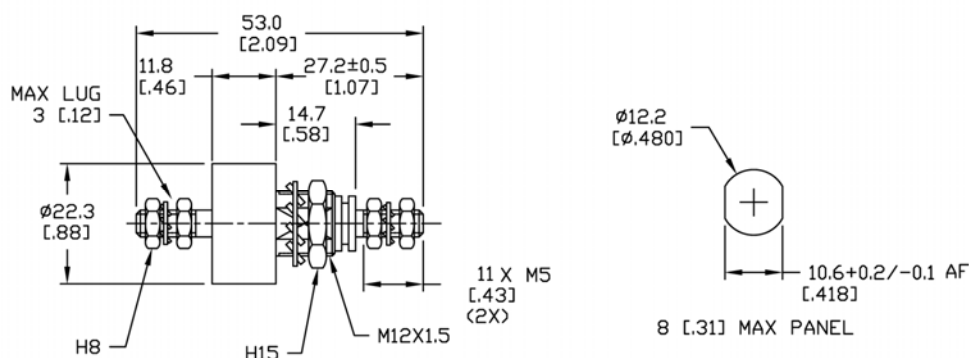

Component	Material	Finish
Metal Parts	Copper Alloy	Nickel
Insulator	FR4 or Nylon	-

### Mounting

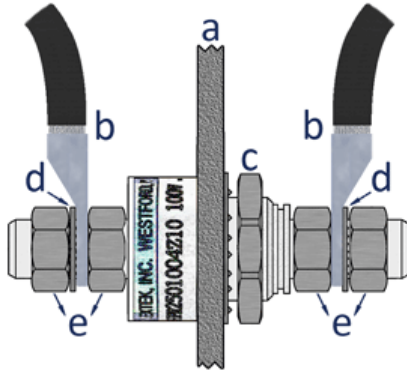

- a. Mounting Panel
- b. Lug / Wire
- c. Mounting Nut
- d. Lock Washer
- e. Electrode Lug Nut

Mounting & Electrode Torque: 50"lbs (5.6Nm)

### Part Number

Device	Current	Capacitance	Tolerance	Voltage	Series
HPR	055	XXXX	X	XX	X

- Device** HPR High Current Feedthrough Filter
- Current** Current rating in amperes
- Capacitance** in picofarads, first two digits are significant, last two digits are number of zeros  
e.g. 2203 = 22,000pF / 4704 = .47μF
- Tolerance** Capacitor Code: Z= +80%/-20% (Standard), M= +/-20%, K= +/-10%, J=+/-5%
- Voltage** Rating Code: 05=50V, 10=100V, 20=200V, 50=500V, 1K=1000V, 1A=120Vac, 2A=240Vac
- Series** Optional series designator

#### Example:

HPR0551004Z10E = Feedthrough Filter / 55A / 0.10uF / +80%/-20% / 100Vdc / E-Series

### Safety Tips

- ✓ The filter should be mounted in a grounded shielding panel
- ✓ Tighten the electrode nuts to the torque specified with the two wrench method
- ✓ Cover exposed electrode nuts
- ✓ Observe temperature, current, & voltage limits