

DC Pass High RF Power Surge Arrestor with 7/16DIN connectors 0.82 – 2.2GHz



- ✦ Passes dc current
- ✦ 50X The Industry Life Expectancy
- ✦ Maintenance Free
- ✦ Excellent RF Performance
- ✦ >80kA Surge Capability
- ✦ Rugged and Waterproof
- ✦ Bi-directional Protection
- ✦ High RF Power and Low PIM

RF Specifications

- ✦ Nominal Impedance – 50 Ω

Frequency	0.82 – 2.2GHz	
RF Power	2 kW rms / 25 kW peak	
Return Loss	-32dB typ	-23.2dB min
VSWR	1.05:1 typ	1.15:1 max
Insertion Loss	0.05dB typ	0.10dB max
PIM (2x43dBm)	> -150dB (3 rd order)	> -173dB (5 th order)

- ✦ Through Current: 65V / 20 A Max

Transient Current Protection

Transient Current*	Strikes	PGT Status	Equipment Status
120kA	1	Replace	Protected
80kA	1	Operational / Replace	Protected
60kA	10	Operational	Protected
30kA	50+	Operational	Protected

* 8x20μs current waveform

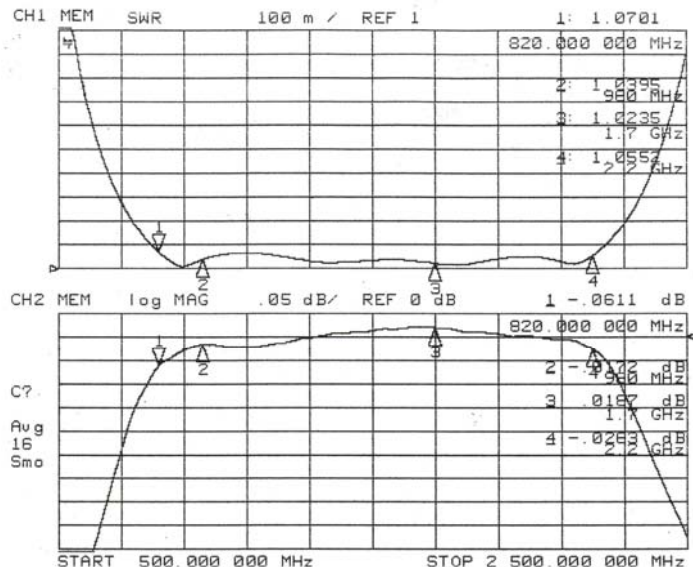

Typical VSWR and Insertion Loss

Mechanical Specifications

✦ Weight: 0.8 lbs. (360g) typical

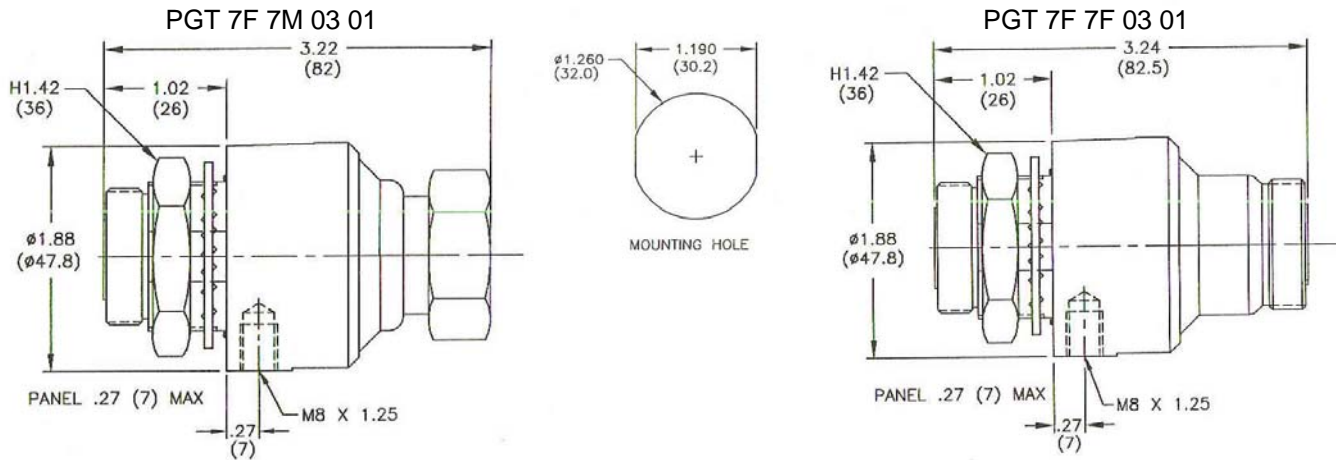

Environmental Specifications

Temperature Range	-40°C to +90°C
Salt Fog	MIL-STD-202 Method 101D / Condition B (35°C/96 hrs)
Immersion	MIL-STD-202 Method 104A / Condition A (65°C to 25°C w/NaCl – 2 cycles)
Moisture Resistance	MIL-STD-202 Method 106E (65 °C/98% RH condensing/240 hrs)
Temperature Shock	MIL-STD-202 Method 107D / Condition B-1 (25 cycles -65°C to +125°C)
Life (Elevated Temperature)	MIL-STD-202 Method 108A / Condition A (96 hours at 100°C)
Dust and Waterproof Rating	IEC529 IP68 (dust-tight and water proof 24 hrs / 1 m)
Vibration	MIL-STD-202 Method 204D / Condition D (10Hz-2kHz 0.06"DA/20g)
Mechanical Shock	MIL-STD-202 Method 213 / Condition A (50g/11ms ~24")

Material and Finish

Component	Material	Finish
Outer Parts	Brass	Guardplate™
Center Contact	Brass / Bronze	Silver
Insulator	PTFE	
Gasket	Si Rubber	

Guardplate™ is an alloy finish with the PIM and conductivity of Silver and the durability and anti-tarnish properties of Nickel.

Transient Performance

Throughput Voltage
600Vpk / 350µJ (6kV / 3kA impulse energy into 50Ω)
DC Current Performance
65Vdc / 15Adc maximum at 5mV drop maximum

Part Number

PGT 7F 7x 03 01

