

**Gas Discharge Tube Lightning Arrestor
N Connectors, a Replaceable Protective Element,
and 3/4" (19mm) Diameter Mounting**



Features:

- ✦ Frequency to 3.2 GHz
- ✦ Excellent RF Performance
- ✦ Multiple Strike Capability
- ✦ 50 kA Surge Protection
- ✦ Bi-directional Protection
- ✦ Rugged and Waterproof
- ✦ High RF Power and Low PIM

RF Specifications

✦ Nominal Impedance 50Ω

Frequency	VSWR	Insertion
dc – 2.5	1.15 Max	0.10 Max
2.5 – 3.0	1.20 Max	0.15 Max
3.0 – 3.2	1.35 Typ	0.25 Typ

- ✦ Through Current: 65V/10A Max
- ✦ RF Power: See Protection Voltage table
- ✦ PIM3: -116 dBc (2X43 dBm 1.9 GHz tones)

Transient Specifications

(1.2X50μs Voltage / 8X20μs Current waveform)

- ✦ Maximum Transient: 50 kA
- ✦ Multiple Strike: 20 kA 10 times
- ✦ Let-through: See Protection Voltage table
- ✦ Replaceable Gas Discharge Tube 90V to 1000V

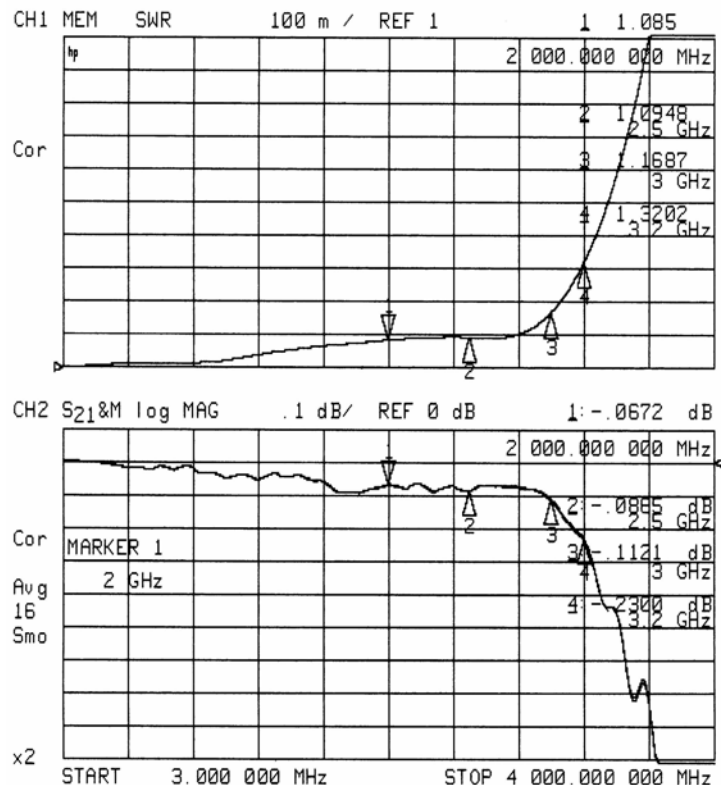

Typical VSWR and Insertion Loss

Mechanical Specifications

✦ Weight 0.3 pounds typ/140 g typ

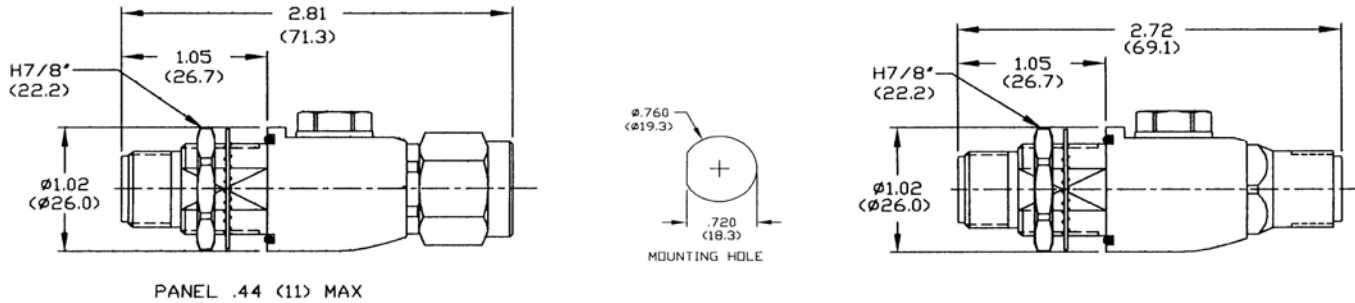

Environmental Specifications

Temperature Range	-40°C to +90°C
Salt Fog	MIL-STD-202 Method 101D / Condition B (35°C/96 hrs)
Immersion	MIL-STD-202 Method 104A / Condition A (65°C to 25°C w/NaCl – 2 cycles)
Moisture Resistance	MIL-STD-202 Method 106E (65°C/98% RH condensing/240 hrs)
Temperature Shock	MIL-STD-202 Method 107D / Condition B-1 (25 cycles -65°C to +125°C)
Life (Elevated Temperature)	MIL-STD-202 Method 108A / Condition A (96 hours at 100°C)
Dust and Waterproof Rating	IEC529 IP68 (dust-tight and water proof 24 hrs / 1 m)
Vibration	MIL-STD-202 Method 204D / Condition D (10Hz-2kHz 0.06"DA/20g)
Mechanical Shock	MIL-STD-202 Method 213 / Condition A (50g/11ms ~24")

Material and Finish

Component	Material	Finish
Outer Parts	Brass	Guardplate™
Center Contact	BeCu	Gold
Insulator	PTFE	-
Gasket	Si Rubber	-

Guardplate™ is an alloy finish with the PIM and conductivity of Silver and the durability and anti-tarnish properties of Nickel.

- ¹ Use the voltage code in the part number
- ² For multiple carriers, sum of peak voltages should not exceed 60% of the protection voltage
- ³ Input is 6kV @ 1.2x50µs/ 3kA @ 8x20µs.

Protection Voltage

Protection Voltage	Voltage Code ¹	RF Power (W) ²	Let-through (V _{pk} / mJ) ³
90	09	37	600 / 0.3
150	15	95	600 / 0.3
230	23	240	650 / 0.5
350	35	550	800 / 0.7
470	47	1000	1200 / 2.2
600	60	1600	1500 / 4.4
800	80	2900	1900 / 9.0
1000	99	4500	2200 / 14

Part Number

PTR ONXONF XX M

- M Specifies ¾" (19mmφ) mount for PTR N Series
- Voltage Code - select based on the RF power. Use 23 for most applications
- Connector Codes – ONF ONF for female to female, ONM ONF for male to female
- PTR Family - (Protector w/ replaceable Gas Discharge Tubes)

Shown with optional bead chain kit
(P/N 780-0333)

