

COMPACT FILTERING FOR HIGH CURRENT & HIGH FREQUENCY APPLICATIONS

BY GEORGE M. KAUFFMAN, PE

WHY HIGH CURRENT FILTERING...?

In today's world of increasing electrical noise, higher speed logic, and more sensitive circuits the need for high frequency noise filtering is especially critical. Noise can enter a circuit through external connections such as the input power source or other transmission lines within the circuit. In addition, undesired noise may be created by switch mode power conversion or other power system circuits. The generation of electromagnetic emissions from the system being designed is of equal concern.

These applications require high frequency noise filtering to comply with the myriad of various industry or governmental standards and regulations (FCC, IEC, MIL-STD, CE, etc.).

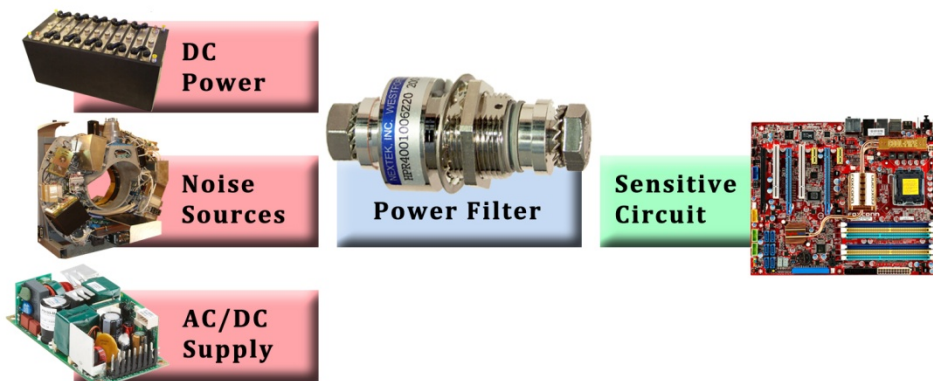

In this article we will explore basic high current filtering techniques and cost effective methods of achieving desired noise reduction levels. Currents ranging from 50A to over 400A are examined because this level is typically above common chassis wiring. The conductors used for this level of current are either bus bars or wire larger than 8AWG (8mm²). Only high performance filters (those achieving 40dB insertion loss or more) are considered here because this level of filtering cannot be easily obtained by simple series impedance or inductance, and achieving 40dB reduction is the minimum requirement for most applications.

High current feedthrough filters have characteristics different from lower current feedthroughs. They are jam nut mounted to a panel and have a massive cross sectional area through the electrodes in comparison to lower current feedthroughs. Lug attachment is best accomplished with threaded connections. It is important that the electrode nuts be capable of high torque to prevent failure and to provide minimal resistance for the wire connection. Solder and fast-on tabs are best relegated to lower current feedthroughs.



FILTERING BASICS

The key component of all high performance low pass filters is the shunt capacitance. Suitable levels of filtering can generally be achieved using a C-Type filter in which the filter can remain compact and light weight, with scaling remaining relatively independent of the higher current levels. Inductors may be important if there are large differences in impedance between the line and the load or higher insertion loss is required. As current levels rise, so do the size and weight of the inductors. For example, an inductor rated for 40A can weigh over 25lbs., when increased to 200A the weight is more than doubled. Due to the large size and weight, inductance is not a preferred solution for most systems, especially aerospace.

Figure 1. Capacitor Filter

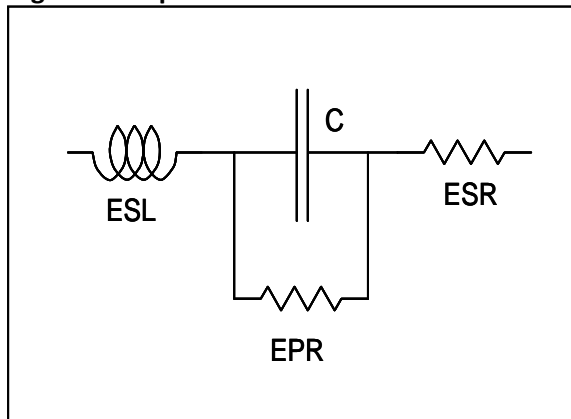

A simplified circuit schematic of a capacitor is shown in figure 1. The intended capacitance is indicated by C. We should take note of three parasitic constituents; ESL (Equivalent Series Inductance), that reduces or eliminates high frequency filtering action, ESR (Equivalent Series Resistance) which limits high frequency filtering action, and EPR (Equivalent Parallel Resistance) that causes leakage current flow, and is not typically an important factor in filtering effectiveness; though leakage must be accounted for and remain at acceptably low levels.

A capacitor has two critical filtering performance parameters: its cut-off frequency and self resonant frequency. The cut-off frequency is

usually based on 3dB of insertion loss, and is closely approximated by:

$$f_{co}(-3dB) = \frac{6350}{C} \quad (1)$$

Where f_{co} is the desired cut-off frequency in MHz for a filter of C capacitance (in pF). For a C-Type filter, the insertion loss increases by 20dB for each factor of 10 (decade) increase of frequency above f_{co} . The insertion loss of a capacitor would be 30dB at about 31.6 times the cut-off frequency. So, for a 220,000 pF (220nF) filter capacitance, the f_{co} would be roughly 28.8kHz. The insertion loss would be 20dB at 288kHz, and 30dB at 912 kHz. These frequencies scale inversely with capacitance, so a 22nF capacitor would have an f_{co} of 288kHz, and a 30dB insertion loss at 9.12MHz.

The insertion loss and frequencies mentioned above are accurate up to approximately 40dB of filtering performance. However, the second critical performance parameter of self resonant frequency limits is the increase of insertion loss with higher frequencies. The self resonant frequency is the result of resonance of the capacitor C with the parasitic series inductance ESL. This inductance is caused by internal inductance and any lead attachment lengths. The governing equation for self resonance is:

$$SRF = \frac{1}{2\pi \times (C \times L)^{1/2}} \quad (2)$$

Where SRF is the self resonant frequency in Hertz, C is the capacitance in Farads, and L is the equivalent total series inductance in Henries. The inductance for a leaded capacitor is difficult to reduce to less than 4nH, especially in high current applications. The SRF for a leaded 220nF capacitor in this example is calculated to be approximately 5.4MHz. One goal of a feedthrough capacitor is to substantially eliminate this lead inductance, and any self resonant frequency effects.

Figure 2 shows the filtering performance of both a leaded and a feedthrough type 220nF capacitor. The filtering performance is essentially identical for both capacitors, from the cutoff frequency up to the SRF of the leaded capacitor

Figure 2. Insertion Loss of 220nF Leaded and Feedthrough Capacitor

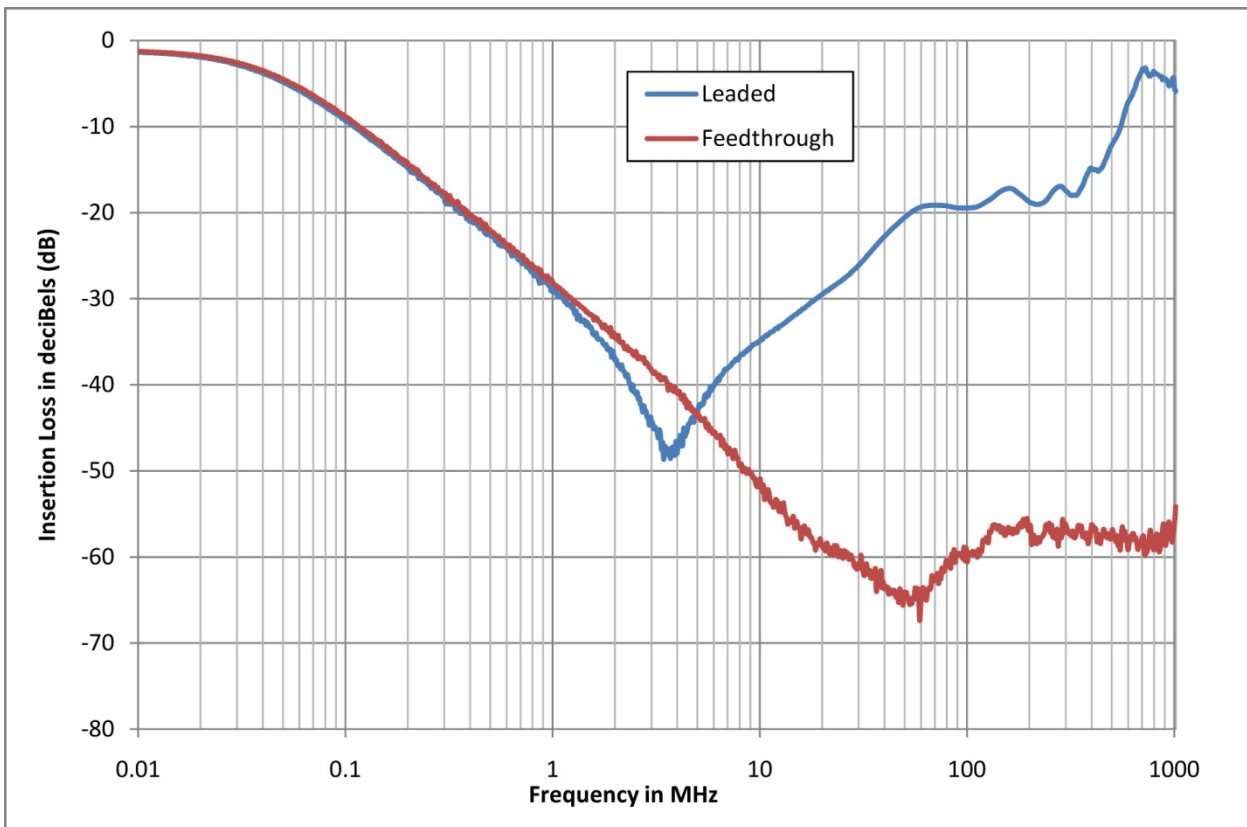

at ~4MHz. The feedthrough continues to increase and maintain insertion loss at the higher frequencies whereas the leaded component tends to have a symmetrical curve with an inflection point at the SRF. After a brief peak of filtering performance at the SRF, the filtering action of the leaded capacitor decreases approximately at the same rate as the rise of performance, making a V shaped insertion loss plot. Conversely, the feedthrough capacitor has effectively maintained insertion loss and shows little signs of the effects of ESL. Figure 2 highlights how the discrete leaded capacitor performs well only at low frequencies, while the feedthrough capacitor has high filtering performance to 1GHz and beyond. These results confirm that leaded capacitors are suitable for filtering up to 1MHz or possibly 10MHz, while feedthrough capacitors extend the high insertion loss filtering range beyond 1GHz.

ESR THE LIMITING FACTOR

The maximum filtering action for a capacitor is typically limited by the equivalent series resistance (ESR) of the capacitor. An ESR of 0.01Ω will tend to limit insertion loss to about 68dB. Most high quality filter capacitors will perform at least to this level.

Figure 3 shows the ESR of the NexTek 220nF filter tested in figure 2. Notice how the ESR limits the maximum insertion loss, as is also reflected in figure 2 by the plateau at about 60dB at frequencies greater than 100MHz.

Figure 3. Equivalent Series Resistance

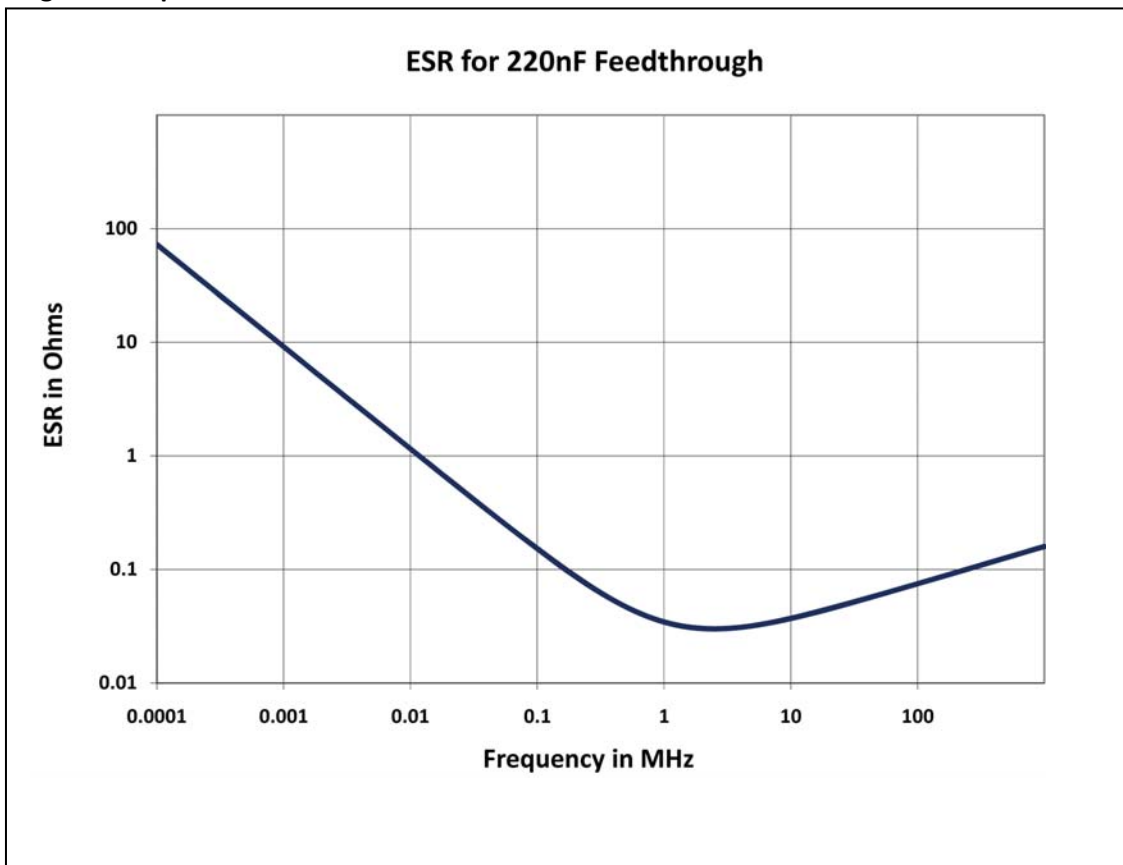

ACHIEVING HIGHER INSERTION LOSS

The insertion loss curve in figure 2 shows a first order shunting capacitor filter. The characteristics are a cutoff frequency based solely on the capacitance value per equation 1, and an insertion loss slope of $\sim 20\text{dB}$ per decade. If more insertion loss is required there are three choices:

1. Increase the capacitance, thereby reducing the cutoff frequency.
2. Include a series inductor to increase the slope of the insertion loss curve. The value of the inductor must be optimized to work with the value of the capacitors, and should be designed according to Butterworth or Chebyshev criteria.
3. Use small value inductors to assist with increasing the maximum insertion loss. These inductors can be approximately 10% of the optimized inductors.

For high power applications with higher insertion loss requirements, the most efficient circuit is a π filter, as these use only one series inductor and two relatively compact capacitors.

Increasing capacitance is the preferred method for gaining higher insertion loss at lower frequencies due to the minimal impact in terms of size, volume, and economics. This is especially true for dc circuits of 200 volts or less. Increasing the capacitance would shift the green performance curve in figure 4, and both curves in figure 2, to the left, increasing the insertion loss at to lower frequencies.

Figure 4. Comparison of 3 Filter Types

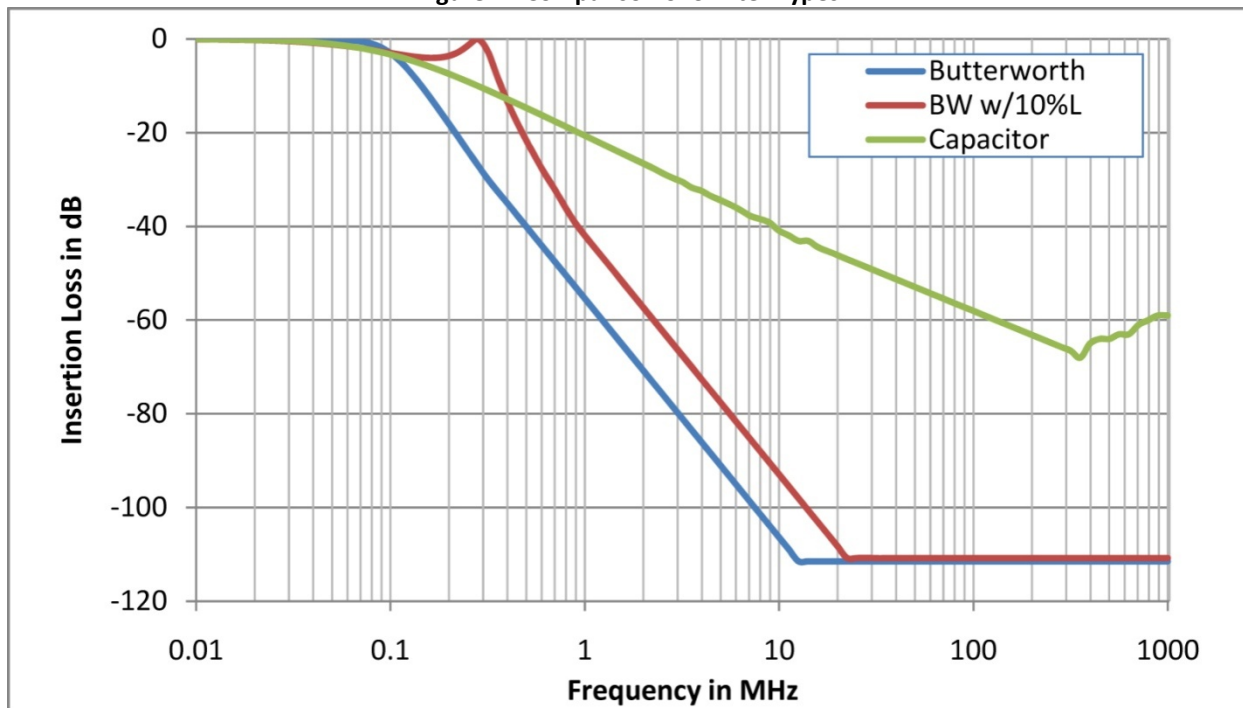

To increase the slope of insertion loss a substantial series inductance is required. For example, to enhance the performance of the previously discussed feedthrough capacitor a Butterworth π filter could be constructed with two 220nF capacitors and a 1.2mH series inductor. The performance of this filter would increase dramatically and the f_{co} would be reduced to about 14kHz. The result would be 30dB insertion loss at 46 kHz, or approximately 3 times the f_{co}

frequency. However the size and weight of the inductor will be significant, especially for higher current applications. The optimized π filter insertion loss is shown by the blue line in figure 4.

An alternative to the optimized inductor is to use an undersized inductor of approximately 10% of the Butterworth value to increase the slope and also maximum insertion loss. This is shown as the red curve in figure 4. The insertion loss plot will show a pronounced dip before the steep slope of insertion loss begins.

Inductors are available that have ~10% change in inductance from no current to full current. The volume of such an inductor is approximately:

$$V_{in}^3 = 0.01 \times \text{current} \times \mu\text{H} \quad - \text{ or } - \quad (3)$$

$$V_{cm}^3 = 0.16 \times \text{current} \times \mu\text{H}$$

Where V_{in}^3 is the approximate volume in cubic inches and V_{cm}^3 is the volume in cubic centimeters, current is the current rating of the inductor in Amperes, and μH is the desired inductance.

To increase the filtering at high current and low frequencies, larger and larger inductors are required. For low current filters, a 1mH inductor is very easy to manufacture and integrate. When the current level exceeds 50 Amperes the inductor begins to present physical and economic challenges. As the current level requirements enter the 200 to 400+ Ampere range the inductor becomes a significant problem.

Inductor Edge Dimension in cm for Butterworth π Filters

Table 1 shows the inductance edge dimension in cm for optimal inductors at various frequencies and amperes required for a Butterworth π filter (the cube root of the volume calculated in equation 3 above). This highlights the substantial size and weight required with the use of inductors.

In comparison, the volume of a feed through capacitor filter does not increase dramatically with an increase of either current or capacitance.

| f_{co} (kHz) | μH | Amperes | | | |
|----------------|---------------|---------|-----|-----|-----|
| | | 50 | 100 | 200 | 400 |
| 10 | 1600 | 23 | 29 | 37 | 47 |
| 20 | 795 | 19 | 23 | 29 | 37 |
| 50 | 320 | 14 | 17 | 22 | 27 |
| 100 | 160 | 11 | 14 | 17 | 22 |
| 200 | 80 | 9 | 11 | 14 | 17 |
| 500 | 40 | 7 | 9 | 11 | 14 |
| 1000 | 20 | 5 | 7 | 9 | 11 |

Table 1. Inductor Edge Dimension in cm.

ADVANCES IN HIGH CURRENT FILTERING

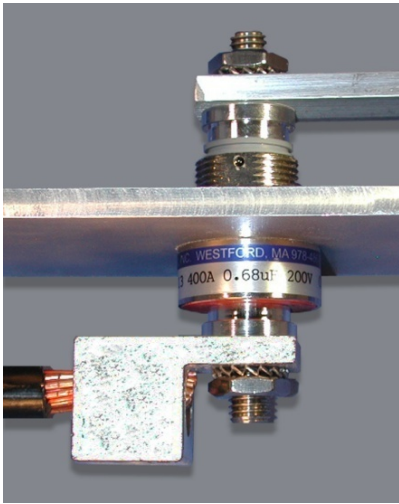

NexTek has improved compact high current filters for many applications.

The feedthrough filter exhibits high filtering action and is easy for both large lug and wire and bus bar attachments.

Since large wires and bus bars can apply significant force to the filter during manufacturing and use, the NexTek feedthrough capacitor uses mechanically decoupled

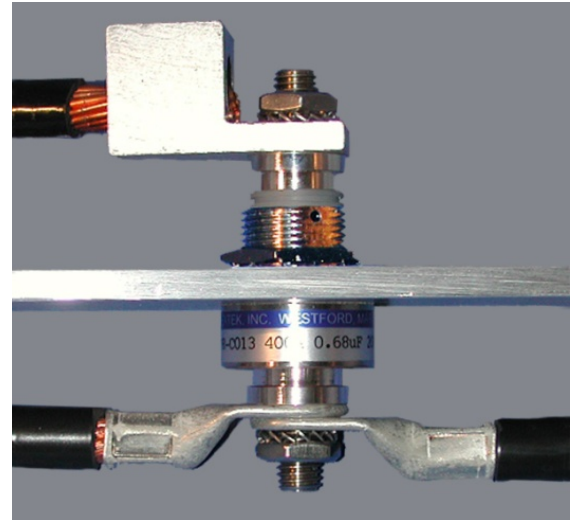

capacitors. These withstand rugged environmental conditions, including shock and vibration, temperature shock, and a wide range of atmospheric pressure changes.

CONCLUSION

A properly configured filter should provide the required insertion loss versus frequency, and handle the through current and applied voltage with adequate margin. A low pass filtering circuit should be centered on high current feedthrough capacitors if significant insertion loss is required above 10 MHz, and in cases where the conductor is carrying 50 amperes or more. The simple feedthrough capacitor will provide the most compact and highest frequency filtering solution, adequate for many applications.

In order to filter out the lowest frequency of concern, the maximum capacitance value should be used. If more insertion loss is required, then series inductors can be used.

RULE OF THUMB

- Use discrete capacitors and inductors to filter frequencies below 1MHz.
- Identify the lowest frequency of concern and begin with the lowest value of capacitance to provide at least 20dB at that frequency. Increase the capacitance as needed to increase filtering, consistent with the compatibility of the circuit.
- Use the largest value of capacitance that will work in the circuit to cover the lowest frequency of concern.
- Consider a π or higher order filter if increased capacitance is not compatible with the circuit, or if attaining even greater insertion loss is required over what can be achieved with a feedthrough capacitor.
- Try to eliminate the restriction of increased capacitance, by either filtering at a dc bus, to eliminate ac leakage current, or reducing the noise at the source.

THE COMPANY

NexTek has designed and manufactured EMC and lightning protection products since 1986. The company specializes in high current feedthroughs and coaxial lightning protectors. The company offers a full range of standard products, and can make unique products for applications with specific mechanical or electrical requirements. You can find out more about NexTek feedthrough filters at: <http://www.nexteklightning.com/products/Filters/filters.html>

THE AUTHOR

George Kauffman is Vice President of Engineering at NexTek, Inc. in Westford MA.

George is a recognized leader in lightning protection and electro-magnetic compatibility and has several patents in the field. He oversees NexTek's engineering and product development. His expertise assures that products achieve optimal technical performance. Prior to NexTek, George's career included engineering, product management, hardware and software development at Digital Equipment Corporation and Compaq.

George holds a BS in Mechanical Engineering and an MS in Engineering Management from the University of Massachusetts/Amherst. He is a registered in Massachusetts as a Professional Engineer.

The key component of all high performance low pass filters is the shunt capacitance. The feedthrough capacitor has high filtering performance to 1GHz and beyond.

WATCH THE WIRES!

Each wire leading to and from the filter can act as an antenna and create a coupling path which will bypass the filter and defeat higher performance filtering.

Therefore, shielding should be used to realize the full benefit of the filter by separating the electrical noise from one side of the filter to the other.